



User Manual



ATB1

**AIS Transceiver
Class B SOTDMA**

English



© 2022 Ocean Signal Ltd

The technical data, information and illustrations contained in this manual were believed to be correct at the time of print. Ocean Signal Ltd reserve the right to change specifications and other information contained in this manual as part of our continual improvement process.

No part of this manual may be reproduced, stored in a retrieval system or transmitted in any form, electronic or otherwise, without the prior permission of Ocean Signal Ltd.

No liability can be accepted for any inaccuracies or omissions in this manual.

Ocean Signal® is a registered trademark of Ocean Signal Ltd.

RECORD YOUR INFORMATION HERE

To ensure easy access to your AIS unit in the future it is recommended that you note the login information.

Boat Name:	
Call Sign:	
MMSI:	
WiFi Network SSID:	
WiFi Network Password hint:	
Email address:	
Password hint:	

NOTE: For dealers installing this product on behalf of a customer it is advisable to use the customer's details to create the account. This will allow the customer to access the unit from their own Mobile device later.

1.	GENERAL	4
	1.1 Exposure to RF Electromagnetic Energy	4
	1.2 Warnings	4
	1.3 ATB1 Overview	5
	1.4 ATB1 Contents	5
	1.5 Example Systems	6
2.	INSTALLATION	7
	2.1 Mounting	7
	2.2 Connections	9
3.	CONFIGURATION	12
	3.1 IMPORTANT NOTE TO DEALERS	13
	3.2 Using WiFi (An Internet connection is required)	14
	3.3 Using a USB Device	15
	3.4 External Data Multiplexing	16
	3.5 Using the Set-up App (Android and iOS)	18
	3.6 Using the On-line Web Based Software	18
	3.7 Creating an Account	18
4.	OPERATION	19
	4.1 Operating Modes	19
	4.2 LED Indicator Sequences	20
	4.3 Connecting with WiFi	21
5.	Glossary of terms and abbreviations	22
6.	Disposal	22
7.	Interface Protocols	23
	7.1 NMEA0183 Data Sentences Supported	23
	7.2 NMEA2000 PGNs Supported	23
	7.3 WiFi Output	24
8.	Specifications	25
9.	Spares and Accessories	25
10.	Approvals	26
	10.1 USA	26
	10.2 Canada	26
	10.3 European Declaration of Conformity	26
	10.4 UK	26
	10.5 Australia / New Zealand	26
11.	Warranty Information	27
	11.1 Limited Warranty	27
	11.2 Extended Warranty	27

1. GENERAL







1.1 Exposure to RF Electromagnetic Energy

This product complies with EN62311:2008 (EU) and RSS-102 (Canada).

This product has been evaluated for compliance with the FCC RF exposure limits given in CFR 47 part 1.307(b) at a distance greater than 25cms from the antenna.

1.2 Warnings

This product is designed to assist navigation and should not be used in the place of appropriate navigational judgment. AIS should be used as a complement to navigation and should not be used to replace installed equipment such as RADAR or ECDIS.

-  **AIS devices can only monitor other AIS equipped vessels. It is the responsibility of the vessels crew and skipper to always be aware of surrounding vessels that may not be fitted with AIS equipment.**
-  **The ATB1 must always be used in conjunction with the supplied GPS antenna. Use of an alternative GPS antenna may impair the functionality of the system.**
-  **This product contains no user-serviceable parts. All maintenance work should be carried out by trained persons authorized by Ocean Signal.**
-  **Do not install in a flammable atmosphere (engine room, near to fuel tanks) or in a location subject to excessive solar heat (direct sunlight, beneath a windshield).**
-  **The ATB1 is a maritime radio transmitter and is subject to radio licensing laws. Contact the relevant authority in your country for local license requirements.**
-  **False information transmitted can result in risk to other vessels as well as your own. It is the user's responsibility to ensure that vessel sensors are configured and calibrated correctly and that all AIS information transmitted is accurate and up to date. It is a criminal offence in some countries to transmit falsified data.**
-  **USA Users only: It is a violation of the rules of the FCC to input an MMSI that has not been properly assigned to the end user, or to otherwise input any inaccurate data in this device. The entry of static data into this device shall be performed by the vendor of the device or by an appropriately qualified person in the business of installing marine communications equipment on board vessels. Instructions on how to accurately enter and confirm static data in the device can be found in Section 3 of this user manual.**

1.3 ATB1 Overview

The Automatic Identification System (AIS) was designed as an aid to collision-avoidance in the marine industry and is a significant development in navigational safety. It is now widely used at sea to provide vessels with a live accurate picture of marine traffic in the surrounding area.

The fully compliant ATB1 is a Class B type AIS Transponder from Ocean Signal. Your vessel information such as position, speed, and course is ascertained automatically and continuously using an internal multi-GNSS receiver and transmitted to all other AIS equipped vessels to maximum of every two seconds.

Other vessel information such as vessel name, call sign, type and dimensions as well as the MMSI are also transmitted. This information can be uploaded to the ATB1 easily by several methods described in Section 3 of this guide. Once this information has been uploaded, it remains stored in the unit's non-volatile memory even if powered down.

The ATB1 also receives and interprets AIS messages from other AIS equipped vessels within range, which can then be relayed effortlessly to other navigation devices such as chart plotters, laptops or mobiles using the ATB1's NMEA0183, NMEA2000, USB or Wi-Fi outputs.

A multi-colour LED indicator light on the ATB1 signals the on-going operational status of the unit. This additional safety feature provides you the confidence of knowing that the ATB1 has continuous AIS transmission and optimal performance.

1.4 ATB1 Contents

1	ATB1
2	Screw Kit
3	Power/Data cable
4	USB to Micro USB Cable
5	USB On-The-Go cable
6	GPS Antenna (Inc. fixing kit)
7	User Manual

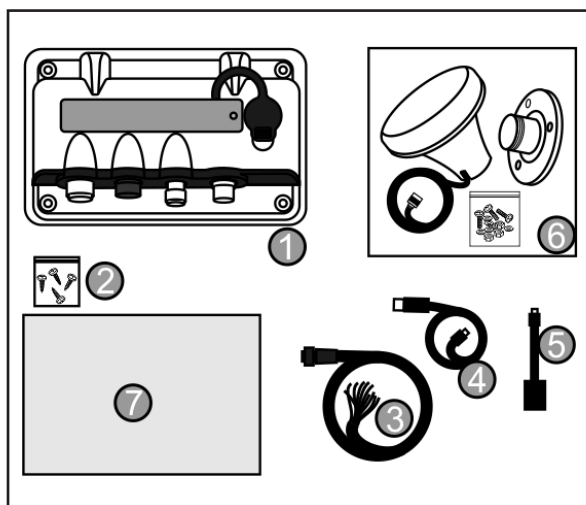

1.5 Example Systems

1.5.1 Example System Using NMEA0183

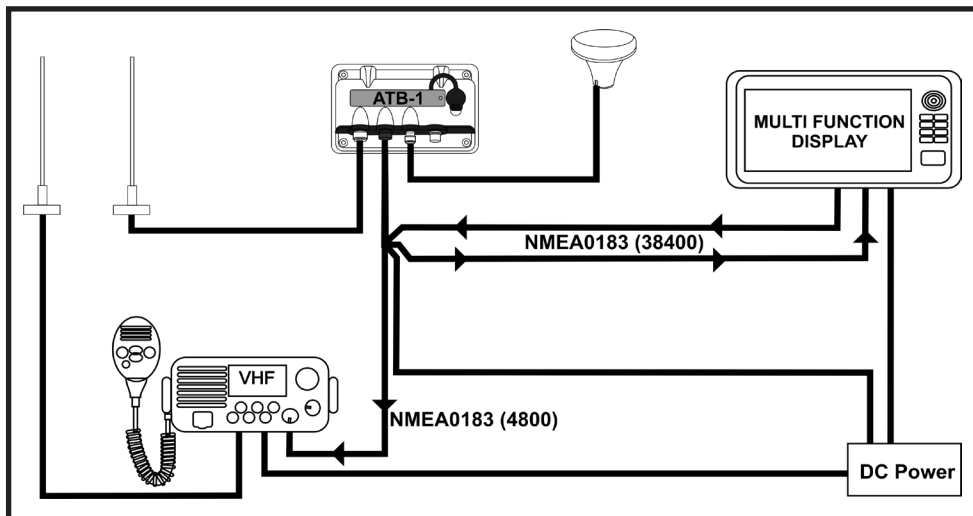

1.5.2 Example System Using NMEA2000

The ATB1 NMEA2000 LEN = 1

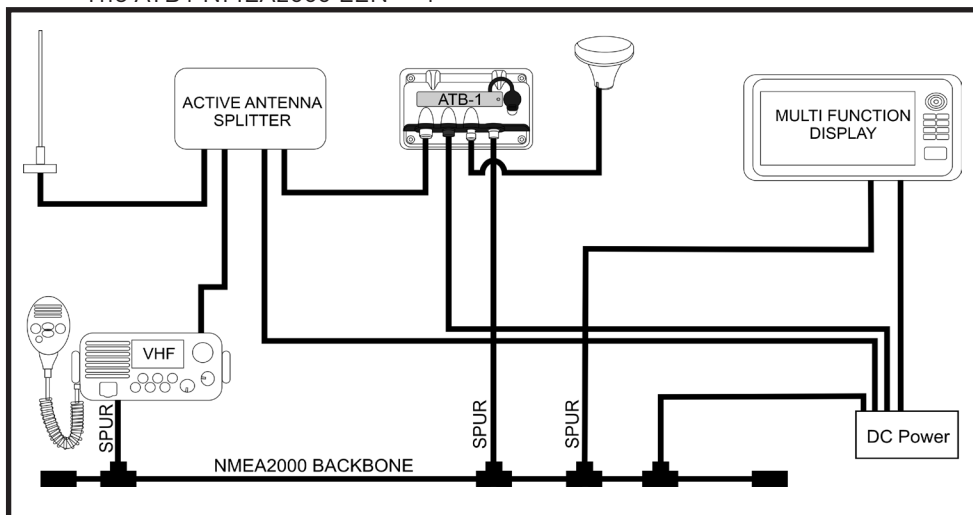

2. INSTALLATION

2.1 Mounting

2.1.1 Transceiver mounting

Determine the mounting location for the ATB1 ensuring that there are suitable access routes for all the required cables and attach securely to a flat surface using the four fixing screws provided. The unit should be easily accessible to allow for disconnection from the power source. The power/data cable plug is the disconnect device, unplugging this will isolate the ATB1 from both poles of the power source. It is also recommended that the unit can be accessed later to view the indicator LED and operate the Mode button.

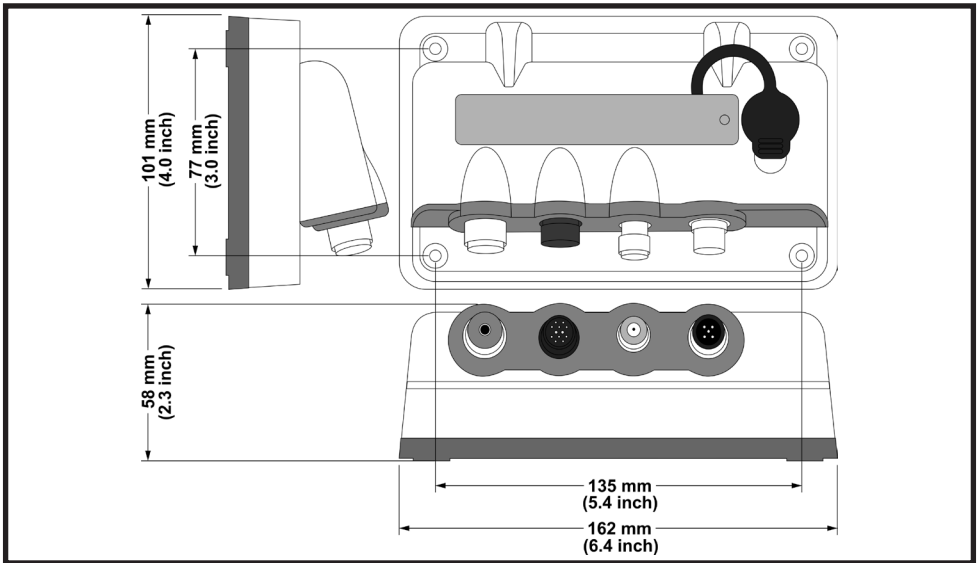

2.1.2 GPS (GNSS) Antenna Mounting

The GPS Antenna should be installed with a clear and unobstructed view of the sky, it should NOT be positioned or mounted on a mast that can cause the antenna to swing and potentially reduce the accuracy of the GPS position and it should NOT be positioned in the direct path of a radar transmitter.

The GPS antenna can be mounted either on a flat horizontal surface or on a suitable pole mount (not supplied).

- If you intend to surface mount the antenna, ensure you have access to the underside of the mounting surface.
- If you intend to pole-mount the antenna, the mount requires a 1 inch 14 TPI thread.

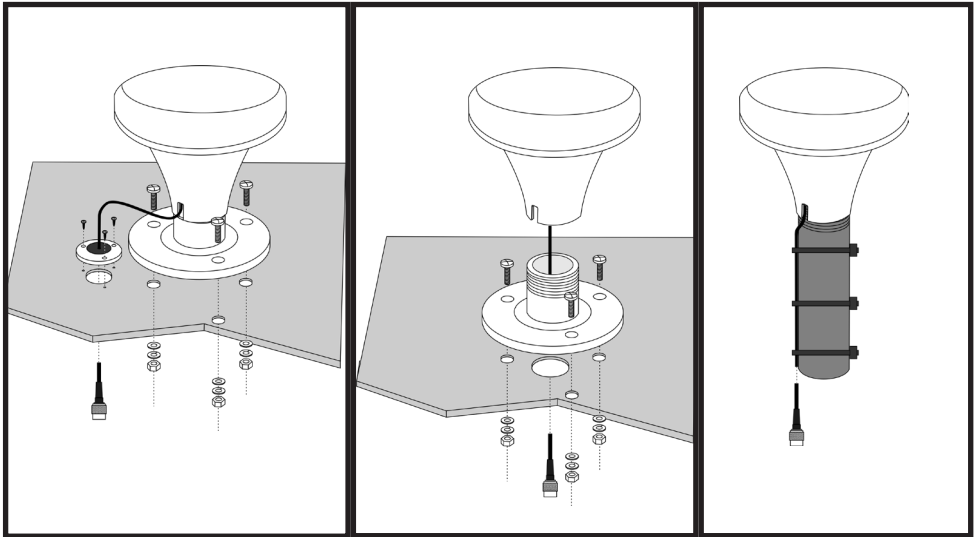

If the cable is passed through the center of a third party mount ensure the thread length does not exceed 2cm (0.78") to prevent damage to the cable



DO NOT cut the GPS Antenna cable. Neatly coil and tie any excess cable

After fixing the GPS antenna to an appropriate location, route the 10m cable to your AIS transceiver unit, adding extension cable as necessary. Connect the cable to the GPS connector on the ATB1.

2.2 Connections

Item	Connector
1	VHF (SO239)
2	Power/Data
3	GPS Antenna (TNC)
4	NMEA2000
5	LED Indicator Button
6	USB (Micro-B)

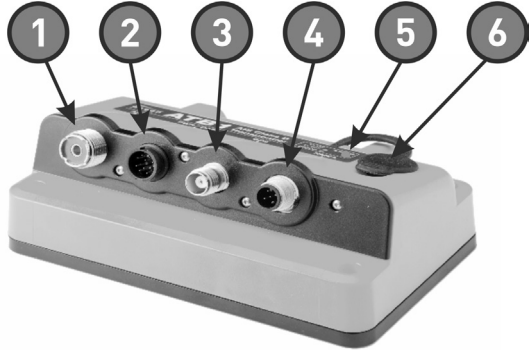

To avoid damage to the cables, ensure at least 50mm (2.0 inches) is available below the Transceiver to allow the cables to turn.

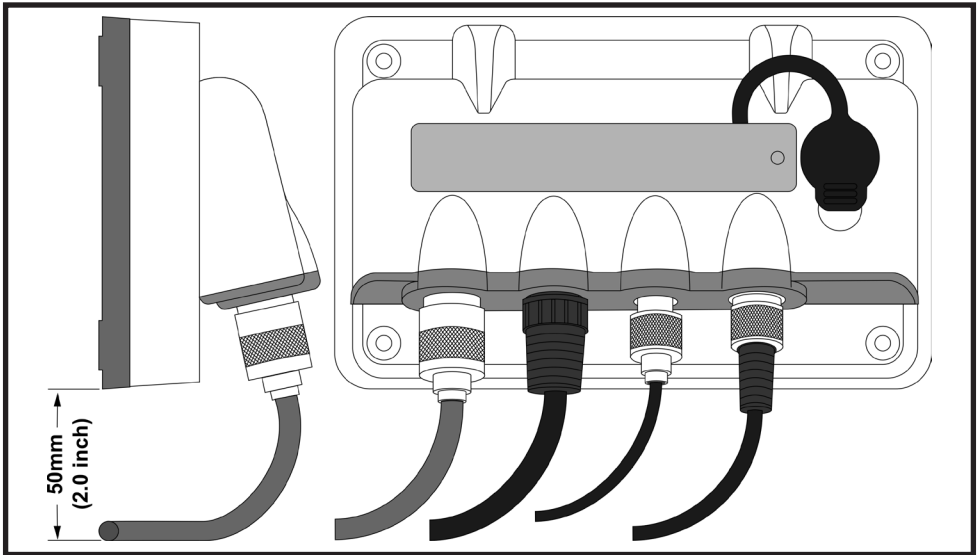

2.2.1 RF Connectors

The VHF antenna should be connected to the SO239 socket.

If the vessel is equipped with a single VHF antenna that is required to be shared between the ATB1 and a VHF Radio Transceiver it is necessary to use an active antenna splitter. Attempting to connect two transmitting devices to a single antenna without a splitter will cause severe damage to either or both devices. Install a third party splitter in accordance with the instructions provided with that unit, connecting the ATB1 “ANT” connector to the AIS Input connector on the splitter.

A typical active splitter installation connection is shown in the NMEA2000 example on page 6 of this manual.



When a splitter is installed and the VHF Radio is transmitting, the ATB1 is unable to make use of the SOTDMA system and reporting rates may be longer than those specified for normal operation. For optimum operation a dedicated VHF antenna is recommended.

The GPS antenna should be connected to the TNC connector.

2.2.2 Power and data connectors

The power and data connections are on the 10-core flying lead supplied.

Connect the power cables to the vessels supply via a suitable fast acting fuse.

If you need to extend the length of the power cable, ensure you observe the following:

- The power cable for each unit in your system should be run as a separate, single length of 2-wire cable from the unit to the vessel’s battery or distribution panel.
- For power cable extensions, it is recommended that a minimum wire gauge of 16 AWG (1.31 mm²). For cable runs longer than 15 meters, you may need to consider a thicker wire gauge (e.g. 14 AWG (2.08 mm²), or 12 AWG (3.31 mm²)).



Default NMEA Port Settings

Power	RED	DC Power	+ve	12 - 24V dc
	BLACK	DC Power	-ve	0V dc
Port 1 Fast NMEA	BROWN	38400	+ve	In
	BLUE	38400	-ve	In
	WHITE	38400	+ve	Out
	GREEN	38400	-ve	Out
Port 2 Slow NMEA	YELLOW	4800	+ve	In
	GREY	4800	-ve	In
	ORANGE	4800	+ve	Out
	PINK	4800	-ve	Out

The ATB1 includes 2 bidirectional NMEA 0183 ports.

The baud rate for each port can be configured via the set-up application. Both ports can be multiplexed to enable GPS data provided to one port to be combined with AIS data and output on the other port.

Typically port 1 is connected to an MFD and configured for 38,400 baud rate, the baud rate required for AIS data transfer. Port 2 is connected to a Heading sensor or other NMEA 0183 device and configured for 4,800 baud rate.

Details of the NMEA0183 sentences accepted and transmitted by each channel are to be found in Section 7.1. NMEA0183 Data Sentences Supported.

2.2.3 External Silent Mode Switch

NMEA Port 2 can be used to allow the user to stop the unit from transmitting from a switch mounted near the helm. This switch will take priority over ALL other user selectable silent mode settings (though a mobile App or using the LED push button). Any latching double pole switch will be suitable.

Silent Mode is selected when the switch is closed

The option for External Silent Mode Switch must be selected during initial configuration.



3. CONFIGURATION

The ATB1 needs to be correctly programmed with the following vessel data before use:

- Vessel Maritime Mobile Service Identity (MMSI) number
- Vessel name
- Vessel call sign
- Vessel dimensions and AIS GPS antenna location
- Vessel type

An MMSI number comprises 9 digits, and all 9 digits of a valid number must be entered to be accepted during setup. All other fields (i.e. vessel type, name etc.) are optional.

If your vessel already has an MMSI number (used for a VHF DSC radio) then the same MMSI number must be used to program the transceiver.

If a valid MMSI number is not entered, the ATB1 will not transmit although it will still operate as a receiver.



Important: In the United States of America, the MMSI and Static Data must be entered only by a qualified dealer or other appropriately qualified installer of marine communications equipment on board vessels. The user is NOT authorized to do this. In Europe and other parts of the world outside of the United States of America, the MMSI and Static Data can be set up by the user.

Configuration can be completed via 3 platforms:

- Android App (download from Play Store) using WiFi or USB stick
- iOS App (download from App Store) using WiFi
- Web Configuration App (on-line at www.oceansignal.com/installers) using USB stick

All user guides can be downloaded direct from the Ocean Signal website www.oceansignal.com.

3.1 IMPORTANT NOTE TO DEALERS

If you are a dealer configuring a unit for a customer you should always create an account on behalf of the end user using their email details and a password that you will pass on to them.

Creating an account allows the end user to access the unit by WiFi easily from their own mobile devices. If no account is created the end user will have to set the unit into configuration mode and use the “New WiFi Configuration” link to be able to access stored details.

For the record:

MMSI Number:	
Vessel Name:	
Call Sign:	
Vessel Type:	
Antenna Dimension A:	
Antenna Dimension B:	
Antenna Dimension C:	
Antenna Dimension D:	
WiFi SSID:	
WiFi Password:	
Account email address:	
Account Password:	



Account details are stored on a GDPR secure server and account holders will only be contacted by Ocean Signal in the event of important update information. Unless expressly accepted no marketing information will be sent via this database and the information entered will not be passed to any third party companies.

3.2 Using WiFi (An Internet connection is required)

Search for Ocean Signal AIS Config.

From the Google Play Store

or

the Apple App Store



Install the Ocean Signal App on your mobile device.

Set-up a WiFi connection with your mobile device (initial connection only)

- Turn off the power to the ATB1.
- Press and hold the LED button and turn on the power. Keep the button held for 6 seconds until the LED turns Amber. Release the button and the LED will remain, Amber blinking off every 2 seconds to indicate the ATB1 is in Wi-Fi connection mode.

Open the App on your mobile device and available devices will be discovered (this may take a few moments). Once the search has completed, select the ATB1 to pair with your mobile device (for iOS only, this is automatic using Android).

Follow the instructions in the App to upload the vessel information to your paired ATB1.

3.3 Using a USB Device

Your vessel information can be transferred from your Android phone or computer/laptop to the ATB1 using a USB stick and the provided USB On-the-Go cable.



Ensure the ATB1 is powered off before inserting the USB stick.

Once inserted, power on the unit. The ATB1 will upload the information from the USB stick automatically. This may take a few moments. Once the LED stops flashing and a steady Green or Green/Amber flashing* light can be seen, the information is stored.

Press and hold the LED button for 10 seconds, the LED will start to flash Red/Amber and on release will alternate Green and Amber to allow the USB stick to be safely removed without corruption. The LED will revert to normal operation once the USB stick is removed.

You can use the Android App (see above) or the web-based software to upload vessel information onto the USB Stick. The web-based software is available at www.oceansignal.com/installers.

* Dependant on whether LRM is turned on.

3.4 External Data Multiplexing

The ATB1 is capable of multiplexing external data sourced from any device connected by NMEA0183 or NMEA2000 to be transmitted by WiFi to a connected navigation App.

To prevent multiple sources and to allow specific sentences to be transmitted it is necessary to turn on the appropriate setting during the configuration process.

In the Advanced Setting section of the mobile and Web based applications you can select the following:

Received NMEA2000 PGNs to be used for data source:

PGN	Data
127250	Vessel Heading
128259	Speed (Water ref.)
128267	Water Depth
130306	Wind Data
128275	LOG
130577	Direction Data
130578	Speed Components
130310	Environmental
130311	Environmental
130312	Temperature
130316	Temperature

NMEA0183 Sentences to be created from the NMEA2000 PGNs above:

Sentence	Data
HDT	True Heading
HDG	Heading
THS	True Heading
VHW	Speed and Heading
VBW	Speed
DBT	Depth
DPT	Depth
MWD	Wind
MWV	Wind
VLW	LOG
MTW	Water Temperature

Received NMEA0183 sentences required to be transmitted by WiFi:

Sentence	Data
HDT	True Heading
HDG	Heading
THS	True Heading
VHW	Speed and Heading
VBW	Speed
DBT	Depth
DPT	Depth
MWD	Wind
MWV	Wind
VLW	LOG
MTW	Water Temperature

3.5 Using the Set-up App (Android and iOS)

Open the Ocean Signal App on your mobile device.

NOTE: An Internet connection is required throughout an initial WiFi set-up procedure. Create a USB stick file (Android only) if there is no Internet signal available.

Carefully enter as many of the details requested by the App as possible. The App can be used at any time to change information OTHER than the MMSI number.



To change a programmed MMSI number it is necessary to use the App to contact Ocean Signal and unlock the ATB1.

3.6 Using the On-line Web Based Software

Recommended Browsers: MS Edge, Firefox, Google Chrome, Safari.
www.oceansignal.com/ais_webapp

Carefully enter as many of the details requested by the App as possible. The App can be used at any time to change information OTHER than the MMSI number.



To change a programmed MMSI number it is necessary to contact Ocean Signal to unlock the ATB1.

The generated file will be saved in the Downloads folder and should be copied onto an empty USB stick *.

3.7 Creating an Account

The creation of an account will increase the warranty period to 3 years. The details entered into the account will also allow Ocean Signal to contact you with any software updates or other important information regarding your AIS.

The database used to store the information entered is fully GDPR compliant and Ocean Signal will not pass on your details to any third parties for marketing purposes.

* USB sticks formatted as xFAT are not supported

4. OPERATION

Once configured the ATB1 will start to operate automatically once the power supply is switched on. The LED will flash Red for a short period while a GPS fix is acquired, after which the LED will remain constant Green flickering slightly every time an AIS signal is received. Alternative operating modes can be selected by pressing the LED button. The operating mode is indicated by the LED as shown in the table in section 4.2.

4.1 Operating Modes

4.1.1 Silent Mode

The ATB1 can be prevented from transmitting the vessels position information allowing it to be used as an AIS receiver only.

To activate Silent Mode press and hold the LED button for 2 seconds until the LED starts flashing Amber/Green. At this point release the button and the LED will flash Red for 5 seconds indicating the unit is entering Silent Mode. Once in Silent Mode the LED will remain continuous Amber to indicate the ATB1 is operating in Silent Mode. To deactivate Silent Mode and start transmitting press and hold the LED button for 2 seconds until the LED starts flashing Amber/Green. At this point release the button and the LED will flash Red for 5 seconds indicating the unit is exiting Silent Mode. Once in normal mode the LED remains continuous Green indicating the ATB1 is transmitting data.

Silent Mode can also be selected using the mobile App or from an externally fitted Switch (See page 11)

4.1.2 Long Range Messaging (LRM) Mode

To ensure the best operation when in offshore waters and out of VHF range from land based AIS stations, the ATB1 can be used in Long Range Messaging Mode to make optimum use of the satellite based AIS receivers.

To activate LRM Mode press and hold the LED button for 5 seconds until the LED shows continuous Amber following 3 seconds of flashing Amber/Green. At this point release the button and the LED will flash Red for 5 seconds indicating the ATB1 is entering LRM mode. Once in LRM mode the LED will flash Green/Amber to indicate the ATB1 is operating in LRM mode.

To deactivate LRM mode and return to normal operation press and hold the LED button for 5 seconds until the LED shows continuous Amber following 3 seconds of flashing Amber/Green. At this point release the button and the LED will flash Red for 5 seconds indicating the ATB1 is exiting LRM mode. Once in normal mode the LED remains continuous Green indicating the ATB1 is transmitting in normal mode.

4.2 LED Indicator Sequences

LED Sequence	Reason	Description
Flashing Green	Start-up	Unit is starting and obtaining a GPS fix.
Steady Green	Operating	Unit is operating and is ready to receive/transmit. Brief interruptions occur as AIS targets are received
Steady Amber	Silent Mode	Brief interruptions occur as AIS targets are received
Green / Amber alternating	LRM Mode	Unit is operating in Long Range Message Mode. Brief interruptions occur as AIS targets are received
Steady Red	Error – Transmit stopped	Use the WiFi App to see details of the fault or check error messages on a connected Multi-Function Display.
Flashing Red	Error – Transmit continued	These errors may be temporary due to external influence. If the error indication continues for more than 60 minutes check error messages on a connected Multi-Function Display
Amber with off pulse every 2s	Wi-Fi Set-up mode	The unit is in Wi-Fi pairing mode and is visible to other devices
Green / Red blink every 1s	External data lost	External data (ie. Heading) that has previously been received by the ATB1 has been lost

4.3 Connecting with WiFi

To connect a mobile device or PC with AIS capable navigation software to the ATB1 via WiFi is dependent on the original set-up of the unit.

4.3.1 With the default WiFi settings

Following a successful configuration, if no specific information is entered, the ATB1 will be visible with the SSID: OS_AISxxxxxxx where xxxxxxxx is the serial number.

4.3.2 With Direct Mode set-up

If an SSID and password has been entered and Direct Mode selected via the Web based or Mobile App then the ATB1 will be visible to other devices with that SSID. Connect your device to the ATB1 using the previously entered password.

Once the device is connected open the third party software application and use the settings within that program to connect to **IP address 192.168.4.1 port 24000**.

When connected GPS information and AIS target information will be available within that application.

4.3.3 With Vessel Network Mode set-up

If the unit has been set-up originally in Vessel Network Mode with the SSID and password of an on-board network the ATB1 will connect automatically to that network on power up. The ATB1 will be allocated an IP address by the network router. Before you can connect another device running AIS capable navigation software it will be necessary to access the router configuration and determine this IP address. The ATB1 will show in the router as "Espressif". Once the IP address has been determined open the third party software application and use the settings within that program to connect to the appropriate IP address port 24000.

When connected GPS information and AIS target information will be available within that application.



When restarted it is possible that a router will allocate a different IP address. For consistent connections use the router configuration software to set a fixed IP address for the ATB1

5. GLOSSARY OF TERMS AND ABBREVIATIONS

AIS	Automatic Identification System	m	Metre
AWG	American Wire Gauge	MFD	Multi-Function Display
DSC	Digital Selective Calling	mm	Millimetres
ECDIS	Electronic Chart Display and Information System	MMSI	Maritime Mobile Service Identity
EU	European Union	PGN	Parameter Group Number
GNSS	Global Navigation Satellite System	RADAR	Radio Detection And Ranging
GPS	Global Positioning Satellite	RF	Radio Frequency
LED	Light Emitting Diode	USB	Universal Serial Bus
LEN	Load Equivalence Number	Vdc	Volts direct current
LRM	Long Range Messaging	VHF	Very High Frequency

6. DISPOSAL

Disposal of the ATB1 at the end of life should be done in accordance with local or national disposal of waste electronic equipment in force at the time.

In the EU the ATB1 should be disposed of in accordance with the Waste Electrical and Electronic Equipment Directive (2012/19/EU). Waste Electronic equipment is not allowed to be disposed of with normal household waste.

7. INTERFACE PROTOCOLS

7.1 NMEA0183 Data Sentences Supported

Port name	Data Speed Baud Rate	Transmit sentences	Receive sentences
Channel 1	Default 34800	ABM, ACA, ACK, ACS, ALR, BBM, EPV, HBT, NAK, SSD, TRL, TXT, VDM, VDO, VER, VSD, DTM*, GBS, GGA*, GLL, GNS, GSV*, GSA*, RMC*, VTG*, POSG	HDG, HDT, THS, ABM, ACA, AIQ, AIR, BBM, EPV, SPW, SSD, VSD, POSG
Channel 2	Default 4800 *GPS only	ABM, ACA, ACK, ACS, ALR, BBM, EPV, HBT, NAK, SSD, TRL, TXT, VDM, VDO, VER, VSD, DTM*, GBS, GGA*, GLL, GNS, GSV*, GSA*, RMC*, VTG*, POSG	HDG, HDT, THS, ABM, ACA, AIQ, AIR, BBM, EPV, SPW, SSD, VSD, POSG

* When set to GPS only via the App, only the marked sentences are transmitted. When a port is set to 4800 it will automatically set the output to GPS only. Valid NMEA0183 sentences received on one port are retransmitted on the other.

7.2 NMEA2000 PGNs Supported

PGN	Title
59392	ISO Acknowledgment
60160	ISO Transport Protocol, Data Transfer
60416	ISO Transport Protocol, Connection Management
60928	ISO Address claim
126208	Request group function
126464	PGN List – Transmit PGN's group function
126992	System Time
126993	Heartbeat
126996	Product information
126998	Configuration Information
129025	Position rapid update
129026	COG SOG rapid update
129029	GNSS position data
129033	Local Time Offset

PGN	Title
129038	AIS Class A position report
129039	AIS Class B position report
129040	AIS Class B extended position report
129041	AIS Aids to Navigation (AtoN) report
129539	GNSS DOP's
129540	GNSS sat's in /view
129545	GNSS RAIM Output
129792	AIS DGNSS broadcast binary message
129793	AIS UTC and date report
129794	AIS Class A static and voyage related data
129795	AIS addressed binary message
129796	AIS acknowledge
129797	AIS binary broadcast message
129798	AIS SAR Aircraft Position
129800	AIS UTC/Date Inquiry
129801	AIS addressed safety related broadcast message
129802	AIS safety related broadcast message
129803	AIS interrogation
129804	AIS assignment mode command
129805	AIS data link management message
129807	AIS group assignment
129809	AIS Class B 'CS' static data report part A
129810	AIS Class B 'CS' static data report part B

7.3 WiFi Output

During normal operation all data being received on either NMEA0183 port will be output via the WiFi signal and be available to any device connected. Multiple WiFi devices may be connected to display this data.

Note: If both NMEA0183 ports are set to 4800 or GPS only then GPS data only will be available on the WiFi output.

8. SPECIFICATIONS

AIS transmission

Transmit Power (EIRP)	5/1Watt
Frequency Range	156.025 – 162.025MHz
Modulation AIS	GMSK: BT 0.4

Receiver

Sensitivity	-107dBm for 20% packet error rate
Frequency Range AIS RX1 and RX2	156.025 – 162.025MHz
Frequency Range DSC	156.525MHz

WiFi

Sensitivity	20dBm (typical)
Frequency Range	2400.0 – 2483.5MHz

General

Dimensions	101 x 162 x 58mm 4.0" x 6.4" x 2.3"
Frequency Range DSC	156.525MHz
Temperature range	-15°C to +55°C 5°F to 131°F
Compass Safe Distance (ATB1 and GPS Antenna)	1m
Waterproof	IPx7 (1 meter for 30 minutes)
Equipment category (ATB1)	Protected
Equipment category (GPS Antenna)	Exposed
Supply Voltage Range	DC 10.8V - 31.2V
GPS Receiver	High Sensitivity
GPS Channels	99 acquisition/33 tracking
Serial Port Interfaces	NMEA0183 (2 Rx, 2 Tx), NMEA2000 (DeviceNet), USB ¹

Compliance

Standards	IEC62287-2, IEC60945
-----------	----------------------

¹ For maintenance/configuration

Essential ratings information can be found on a label attached to the back of the product

9. SPARES AND ACCESSORIES

Part Number	Description
763S-02845	GPS Antenna (with 10m cable)
763S-03088	ATB1 Power Data Cable
763S-03089	USB On the Go Adapter Cable
763S-03090	USB A to USB micro cable
763S-03095	USB Connector Protective Cover

10. APPROVALS

For approval documents see: <https://oceansignal.com/approvals-documents/>

10.1 USA

The ATB1 is approved for use in the USA under CFR47 part 95K,

10.2 Canada

The ATB1 is approved for use in Canada with AIS only under RSS287.

10.3 European Declaration of Conformity

Hereby, Ocean Signal Ltd. declares that the radio equipment type ATB1 is in compliance with Directive 2014/53/EU.

Country of Intended Use (The Country of Intended Use table is an EU requirement only)

Austria	✓	Finland	✓	Latvia	✓	Romania	✓
Belgium	✓	France	✓	Lithuania	✓	Slovakia	✓
Bulgaria	✓	Germany	✓	Luxembourg	✓	Slovenia	✓
Cyprus	✓	Greece	✓	Malta	✓	Spain	✓
Czech Republic	✓	Hungary	✓	Netherlands	✓	Sweden	✓
Denmark	✓	Iceland	✓	Poland	✓		
Estonia	✓	Italy	✓	Portugal	✓		

10.4 UK

The ATB1 is compliant with UK Radio Equipment Regulation 2017

10.5 Australia / New Zealand

The ATB1 is compliant with AS NZS 4208.2 and AS NZS 4869.4

11. WARRANTY INFORMATION

11.1 Limited Warranty

Your Ocean Signal product is warranted against manufacturing defects in materials and workmanship for a period of 2 years from the date of purchase and in accordance with the following conditions.

Ocean Signal will at its discretion, repair or replace faulty product free of charge excluding the cost of shipping. Proof of purchase from the original purchaser shall be required in order for a warranty claim to be valid. All claims shall be made in writing to Ocean Signal or an approved service dealer or distributor.

Ocean Signal shall not be liable to the buyer under the above warranty:

- for any repairs or modifications carried out on the product using parts that are not supplied or approved by the manufacturer Ocean Signal including batteries and for work carried out other than by Ocean Signal or approved service dealers,
- for any part, material or accessory that is not manufactured by Ocean Signal, the consumer will be covered by the guarantee / warranty offered to Ocean Signal by the manufacturer or supplier of such a component,
- for product which has not been fully paid for,
- for any product supplied by Ocean Signal to a customer under an alternative warranty or commercial agreement,
- for the cost of shipping product to and from the customer.

The Battery is only warranted until the date of expiry and provided the unit is tested in accordance with the information in the user manual as noted by the electronic witness stored within the product.

The following specific item is excluded from this warranty:

- Damage to the antenna

This warranty does not affect your statutory rights.

11.2 Extended Warranty



ENTER THE PRODUCT DETAILS TO GAIN THE EXTENDED WARRANTY PERIOD



Apply for free at www.oceansignal.com/warranty

By entering your product details you can add 3 years to the warranty period. For full details on extended warranty on this product see www.oceansignal.com/warranty.

For further assistance please contact our Technical Service Department.
Email: info@oceansignal.com

Ocean Signal Ltd.
Unit 4, Ocivan Way
Margate
CT9 4NN
United Kingdom

info@oceansignal.com
www.oceansignal.com

